

# butterfly valve

## type QUADAX - lug type

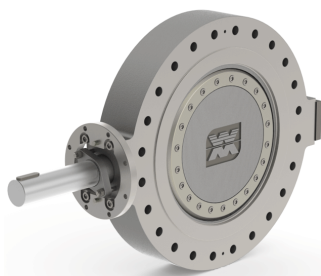

**butterfly valve** bare shaft  
**pressure range** PN 0-63 bar  
**orifice** DN 50-1000 mm  
**connection** flange

**⚠** Above stated body materials refer to the valve port connections that get in contact with the media only!

**body materials** carbon steel, stainless steel, special material (duplex, inconell, bronze)  
**valve seat materials** inconell, others on request  
**seal materials** graphite / stainless steel, inconell, stainless steel, PTFE

**details needed**

- size
- pipe connection
- operating pressure
- flow rate
- Δp
- closing time
- media
- process temperature
- outside temperature

**general specifications**

<b>ports</b>	flange	PN 10 / 16 / 25 / 40 / 63 ANSI 150 / 300 / 600
<b>function</b>	NC / NO / DA	depending upon actuator
<b>pressure range</b>	body pressure	0 to 63 bar
	Δp standard shaft	52 bar in both directions
<b>Kv value</b>	m³/h	see table
<b>leakage rate</b>		1 DIN 3230 A DIN EN 12266 BS 6364 Fire safe
<b>flow direction</b>	A ⇌ B	as marked
<b>switching time</b>	s	DN/100
<b>process- and outside temperature</b>	standard	-10 °C to +450 °C
	with special materials	-270 °C to +800 °C
<b>limit switches</b>		option
<b>approvals</b>		PED / Fire safe / BAM / TA Luft / ATEX in further
<b>weight</b>	kg	see table
<b>additional equipment</b>		upon request

**⚠** The valves' technical design is based on media and application requirements. This can lead to deviations from the general specifications shown on the data sheet with regards to the design, sealing materials and characteristics.

**⚠** If order or application specifications are incomplete or imprecise there exists a risk of an incorrect technical design of the valve for the required application. As a consequence, the physical and / or chemical properties of the materials or seals used, may not be suitable for the intended application.

**Kv-curve**

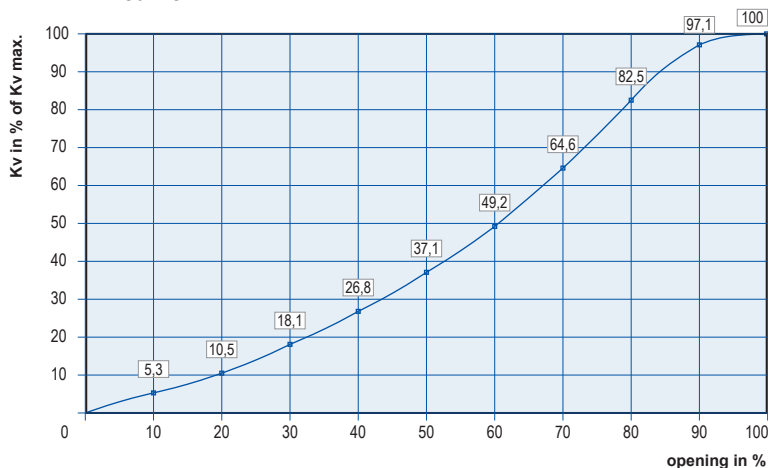

■ specifications not highlighted are standard  
 ■ specifications highlighted in grey are optional

# type QUADAX - lug type

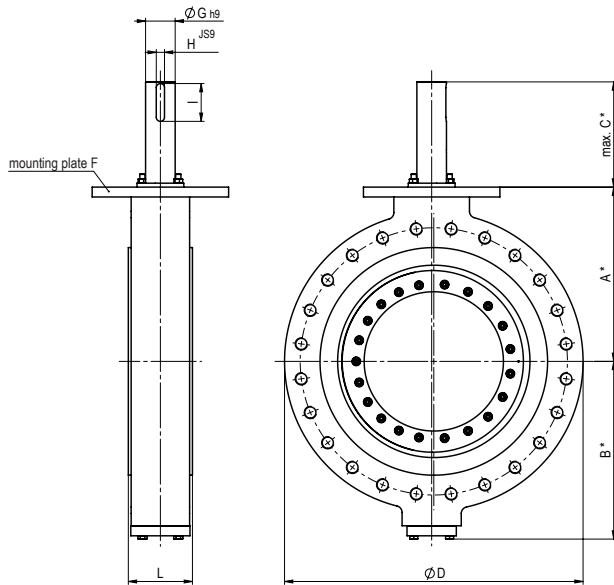

\* dimensions for trim X only

size	(mm) (inch)	50 2	65 2 ½	80 3	100 4	125 5	150 6	200 8	250 10	300 12	350 14	400 16	450 18	500 20	600 24	700 28	750 30	800 32	900 36	1000 40	
pipe cl to mounting plate		A	105	128	128	162	190	203	240	279	305	325	385	405	440	530	630	630	700	830	920
pipe cl to cover screws		B	106	129	129	158	186	204	241	281	307	333	383	403	441	541	643	643	713	836	926
bare shaft length for direct mounting		C	95	95	95	125	135	145	180	180	180	280	289	300	320	320	367	367	367	398	398
bare shaft length for adapter		C	51	51	51	68	68	68	85	85	85	173	170	170	170	170	210	-	-	-	-
flange diameter	PN 10	D	165	200	200	230	250	295	352	405	455	515	565	615	670	780	895	970	1085	1115	1230
	PN 16	D	165	200	200	230	250	295	352	405	455	515	590	640	725	845	910	970	1085	1125	1255
	PN 25	D	165	200	200	230	270	295	352	425	485	550	620	680	725	845	960	1020	1085	1185	1320
	PN 40	D	165	200	200	230	270	295	375	450	515	585	660	680	770	908	-	-	-	-	-
	PN 63	D	180	215	215	250	295	345	415	470	530	600	670	-	-	-	-	-	-	-	-
	ANSI 150	D	165	190	190	230	-	280	352	405	485	550	590	640	700	815	927	984	1085	1168	1290
	ANSI 300	D	165	210	210	254	-	320	380	445	515	585	660	710	770	908	1035	1092	1149	1270	1238
	ANSI 600	D	165	210	210	275	-	355	420	508	560	605	685	745	815	940	1073	1130	1194	1315	1320
mounting plate F ISO 5211	(others on request)	F	F07	F07	F07	F10	F12	F14	F16	F16	F16	F25	F30	F30	F35	F35	F40	F40	F40	F48	F48
trim A	20 bar max. 290 psi max.	G	-	-	-	-	-	-	-	-	40	45	50	55	55	70	90	90	100	110	120
		H	-	-	-	-	-	-	-	-	12	14	14	16	16	20	25	25	28	32	32
		I	-	-	-	-	-	-	-	-	45	60	60	80	80	90	115	115	125	140	160
trim X (standard)	52 bar max. 754 psi max.	G	14	18	18	20	22	32	32	40	45	55	65	70	75	90	110	110	130	150	160
		H	5	6	6	6	6	10	10	12	14	16	18	20	20	25	32	32	32	36	40
		I	25	28	28	28	40	40	40	45	60	80	88	90	90	115	140	140	180	180	200
DIN 3202 K3	PN 10/16/25/40/63	L	43	64	64	64	70	76	89	114	114	127	140	152	152	178	229	241	241	241	300
API 609	ANSI 150	L	43	48	48	54	-	57	64	71	81	92	102	114	127	154	-	-	-	-	-
	ANSI 300	L	43	48	48	54	-	59	73	83	92	117	133	149	159	181	-	-	-	-	-
	ANSI 600	L	43	54	54	64	-	78	102	117	140	155	178	200	216	232	-	-	-	-	-
kv-value (m³/h)	trim A trim X	Δp max. 20 bar Δp max. 52 bar	- 38	- 118	- 118	- 258	- 418	- 654	- 1445	- 2451	3837 3720	5478 5120	7944 7321	10735 9986	12921 12118	20651 19253	25473 23081	32661 30015	36123 33343	47565 43215	56131 51398
	trim A trim X	Δp max. 290 psi Δp max. 754 psi	- 44	- 137	- 137	- 300	- 486	- 760	- 1680	- 2850	4462 4314	6370 5953	9237 8513	12483 11612	15024 14091	24013 22387	29620 26838	37978 31702	42003 38771	55308 50250	65269 59765
weight (standard)	(ca. kg)	8	16	16	22	32	39	68	128	150	221	319	349	457	715	1017	1203	1336	1744	2467	